

RZ Ecosystem Partner Solution

VK-RZ/V2L

Raspberry Pi® 4 Form Factor Compliant



Solution Summary

VK-RZ/V2L is built for industrial use and is compatible with Raspberry Pi® 4 shields for convenient AI integration. Excellent solution for all kind of industrial, professional or hobby projects.

Features/Benefits

- Renesas RZ/V2L 2x ArmCortex®-A55 @ 1.2GHz + Cortex®-M33, 2x Gigabit RJ45 (1x PoE)
- RAM: 2GB DDR4, FLASH: 32MB QSPI & 32GB eMMC, 2x CAN FD, 6x ANI + ADC_TRG
- 1x 22pin FPC Camera (MIPI-CSI), 1x µHDMI 1.4 Video, 1x 30pin FPC Display (MIPI-DSI)
- 1x SDHI, 2x Host USB 2.0 A, 1x 3.5mm Audio, 1x User BTN, 4x User LEDs (R|G|B|Y)
- 1x µUSB 2.0 A: System TTY (+ optional Cortex®-M DBG [FW])

Diagrams/Graphics

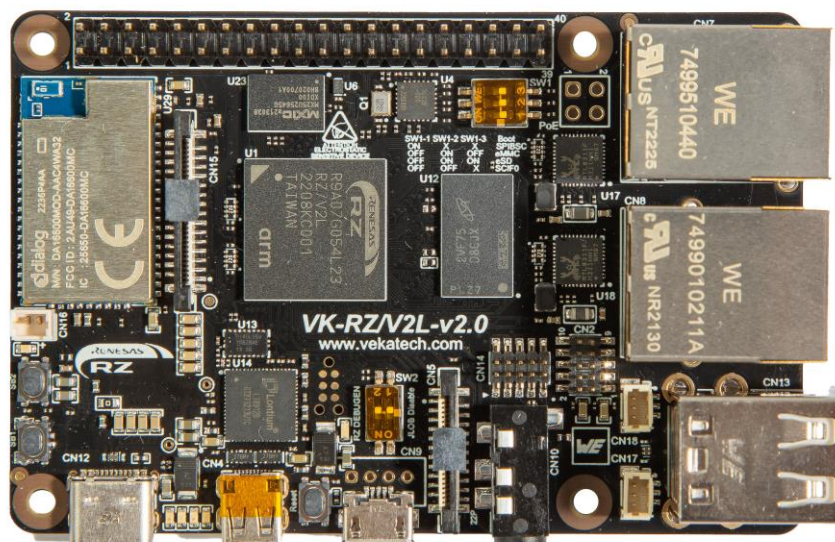

Target Markets and Applications

- | | |
|---------------------------|--------------------|
| ▪ Artificial Intelligence | ▪ Robotics |
| ▪ Home Automation | ▪ IoT Applications |
| ▪ Industrial Automation | ▪ Computer Vision |

Block Diagram

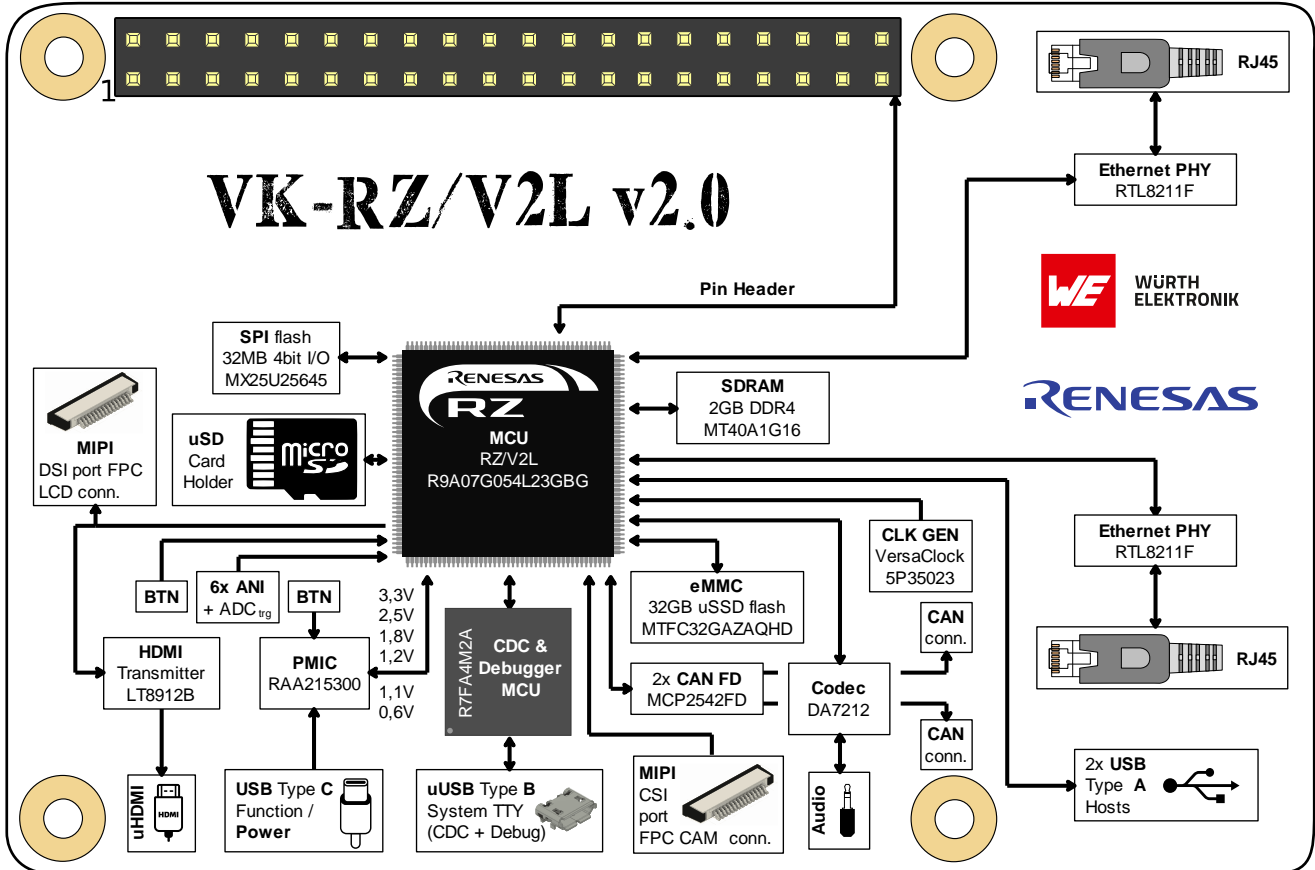

Learn more:

<https://vekatech.com/products/VK-RZV2L>

Contacts:

Vekatech Ltd.

63, Nestor Abadzhiev str.

4023 Plovdiv

Bulgaria

Tel. +359 (0) 32 262362

Fax. +359 (0) 32 262362

E-Mail: info@vekatech.com

Website: <https://www.vekatech.com>